

# AVALON

## CROWD CONTROL BARRIER

high visibility barrier  
with anti-trip feet



- Linking design creates secure, tamper free, connections
  - units adjust to uneven ground
- High visibility, anti-trip feet
- Panels on both sides for retroreflective sheeting
- Holes for signs to be affixed
- Durable polyethylene
- Available in orange, yellow, white, and blue



Avalon adjusts to uneven ground



# AVALON

## CROWD CONTROL BARRIER

Specs	
Composition	Polyethylene
Weight	24 lbs.
Colors	Orange, Yellow, White, & Blue
Sheeting Area	5.5" x 51" on each side
Retroreflective Sheeting	Striped sheeting in engineer grade or high intensity prismatic grade

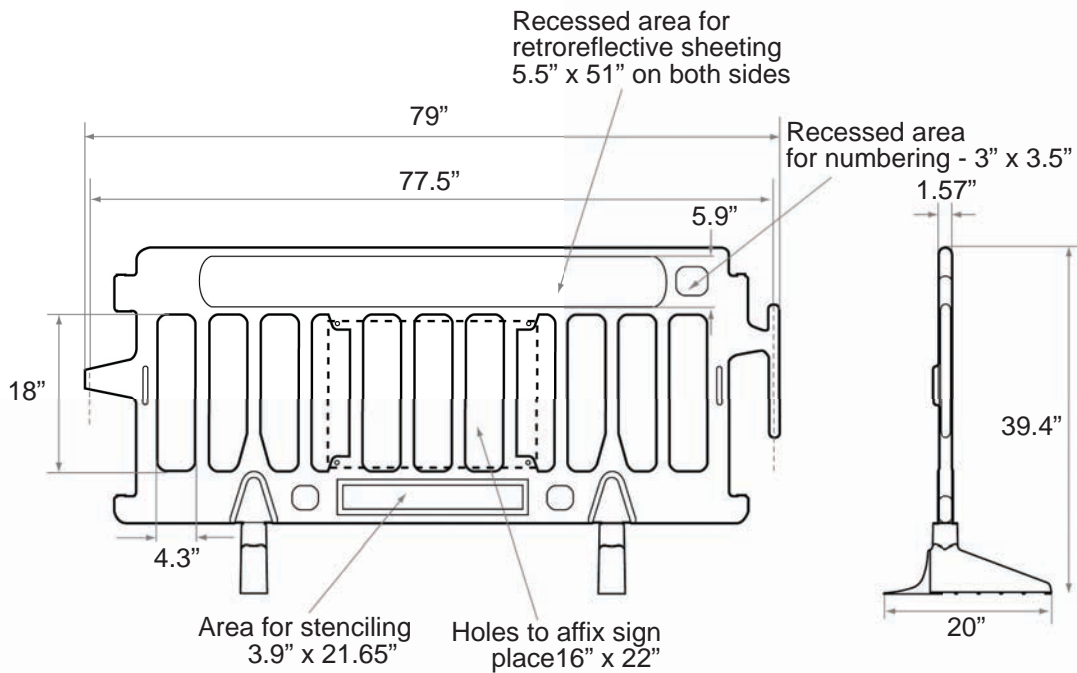

### Various Barrier Configurations

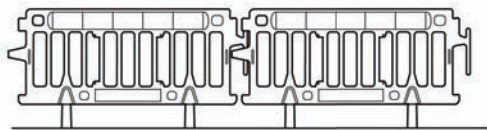

Locked

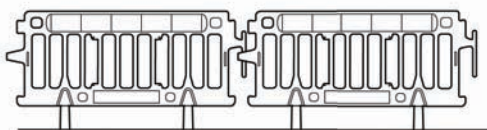

Unlocked

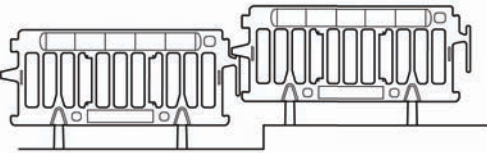

Curb

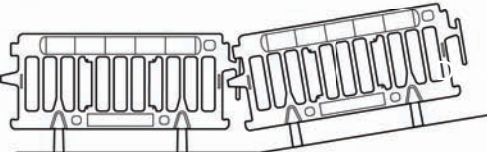

Uphill Slope

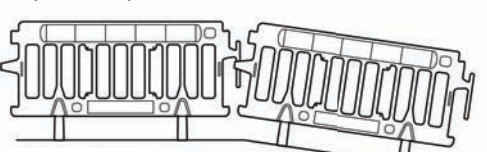

Downhill Slope

3 barriers unlocked extend 232.5"  
3 barriers locked extend 221.7"

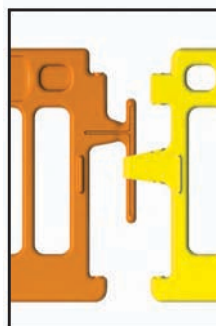

connected unlocked



lift one barrier to lock

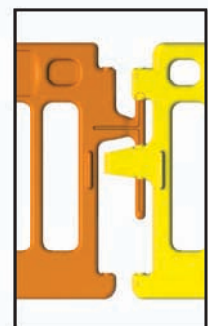

connected locked



**TransSupply**  
 Transportation Supply LLC  
 1401 Lavaca Street #40  
 Austin, TX 78701  
 (866) 930-4604  
[sales@trans-supply.com](mailto:sales@trans-supply.com)  
[www.trans-supply.com](http://www.trans-supply.com)