

PLASTICADE[®]

TYPE I & TYPE II BARRICADE

Maintenance Free
All Plastic Barricade



- Durable barricade designed to withstand repeated impacts from vehicles
- Molded-in handles with mounting holes for attaching flashing lights
- Features "click lock" hinges for a positive interlock in the open position
- Barricade is molded hollow for internal ballasting with up to 10 lbs. of sand
- Sandbag bar (if additional weight is required)
- Available in white, yellow, and orange
- Stacking lugs keep stacked units from sliding
- NCHRP-350 Accepted, meets MUTCD Standards

Signs or names can be stenciled directly on the barricade or on the reflective sheeting



PLASTICADE®

TYPE I & TYPE II BARRICADE

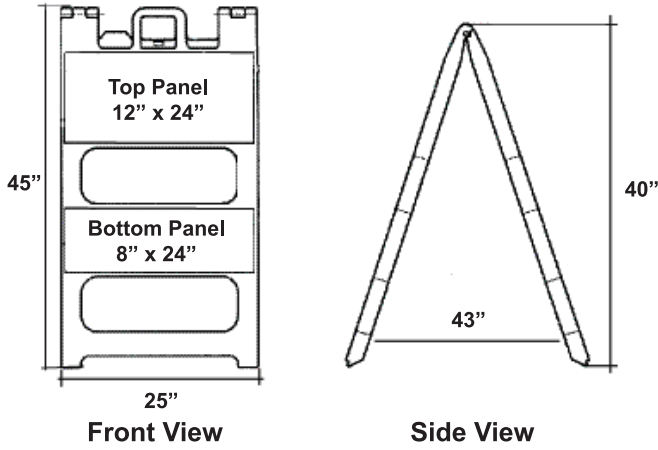

Specs	
Composition	High Density Polyethylene
Dimensions	45\"/>



With the addition of a sign sleeve, the Plasticade barricade becomes a sign stand (NCHRP Certified)

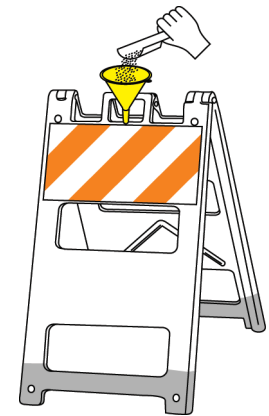

Fill with up to 5 lbs. of sand per side.



Transportation Supply
 4701 Natick Ave. Suite 215
 Sherman Oaks, CA 91403
 (866) 930-4604

sales@trans-supply.com
www.trans-supply.com



MADE IN THE USA