

SUNRAY™

# CONSAM SPEED AWARENESS TRAILER

ITS | SMART WORK ZONE PRODUCT

*Alert motorists of their speed instantly using radar technology and highly-visible LED display signs.*

**ConSAM Construction Speed Awareness Monitor** detects and displays the current speeds of approaching vehicles in relation to the latest posted speed limit to slow motorists down and protect road side workers with reduced speeds and motorists' awareness.

Combining solid-state electronics, LED display, and solar panel battery recharging, this new monitor offers high reliability, low maintenance, and long life along the side of the road.

From the only manufacturer of traffic safety products that combines both **Integration + Intelligence** to solve problems and increase passenger and highway worker safety.

## CONNECTED SMART WORK ZONES

Powerful and flexible ITS highway safety management solution

Our **ITS Smart Work Zone** solutions are designed to enhance transportation efficiency, improve safety, and increase mobility around work zones. At the core is our **HS Connect® software**—a robust, communications-driven platform that remotely links and monitors all connected field devices.

Together with our advanced technologies, **HS Connect®** delivers a complete Smart Work Zone package that empowers contractors and transportation agencies to protect roadside workers and the traveling public—efficiently and intelligently.



To learn more, visit [HS-Connect.com](https://HS-Connect.com)



CONNECTED

## FEATURES

- Battery bank and solar panel array sized to provide continuous uninterrupted operation up to 18 days
- 18" optically enhanced LED display provides legibility up to 1,000 feet
- Solid-state controller with thermal compensation assures optimum charge and extends battery life
- Battery power eliminates refueling, noise, and moving parts
- Automatic intensity control assures distance legibility at all times, regardless of battery bank voltage
- Includes speed recording system, violator alert, and maximum speed display cut-off feature



Transportation Supply LLC  
1401 Lavaca Street #40, Austin, TX 78701  
(866) 930-4604  
[sales@trans-supply.com](mailto:sales@trans-supply.com)  
[www.trans-supply.com](http://www.trans-supply.com)

# CONSAM SPEED AWARENESS

## TRAILER SPECIFICATIONS

Height (travel position)	98" (2.48 m)
Height (display position)	138" (3.50 m)
Width (outside fenders)	67.34" (1.71 m)
Width (outside display sign)	72" (1.82 m)
Length	128 (3.25 m)
Weight	1,000 lbs (453.59 kg)
Tire size	14" (35.56 cm)

## POWER SOURCE SPECIFICATIONS

Battery bank	Two 6-volt
Solar panel array	One 55-watt panel

## RADAR SPECIFICATIONS

Detection distance	1/4 to 1/2 mile
Beam width	12° conical

## DISPLAY CHARACTERS SPECIFICATIONS

Type	LED Lamp Matrix
Display Legibility	1,000' (304.8 m)

## CONTROLLER

Solid-state controller with thermal compensation assures optimum charge and extends battery life

## DIMENSIONS

### Travel Position

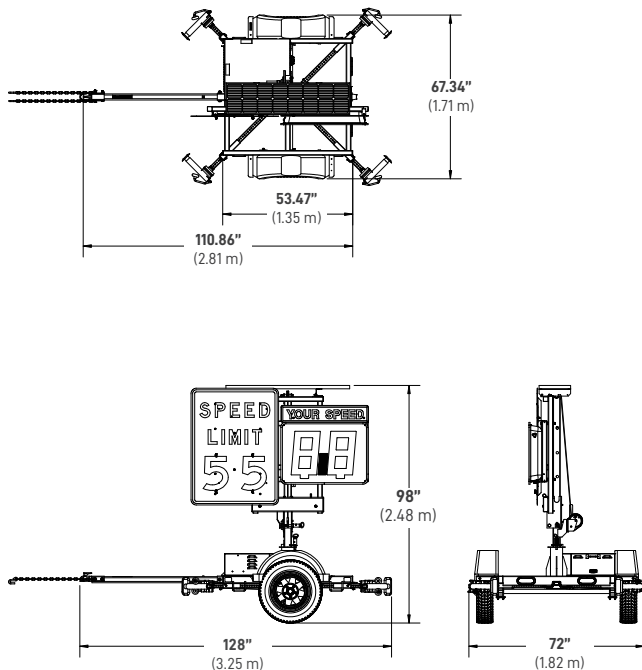

### Deployed Position

